

CAFÉ COUNTERS DROP-IN

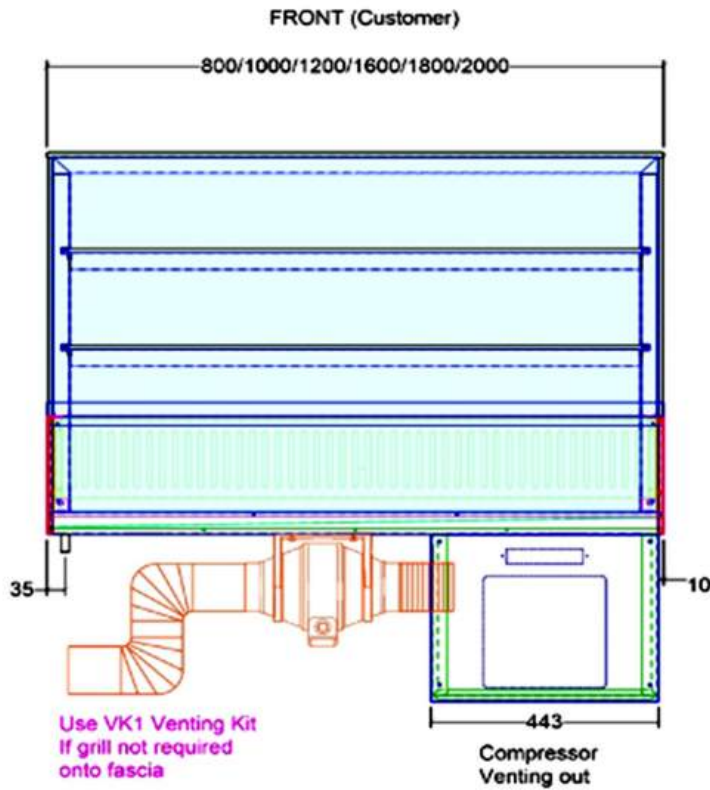

SIDE VIEW CC Drop-in-2S
Refrigerated Base
Two Ambient Shelves

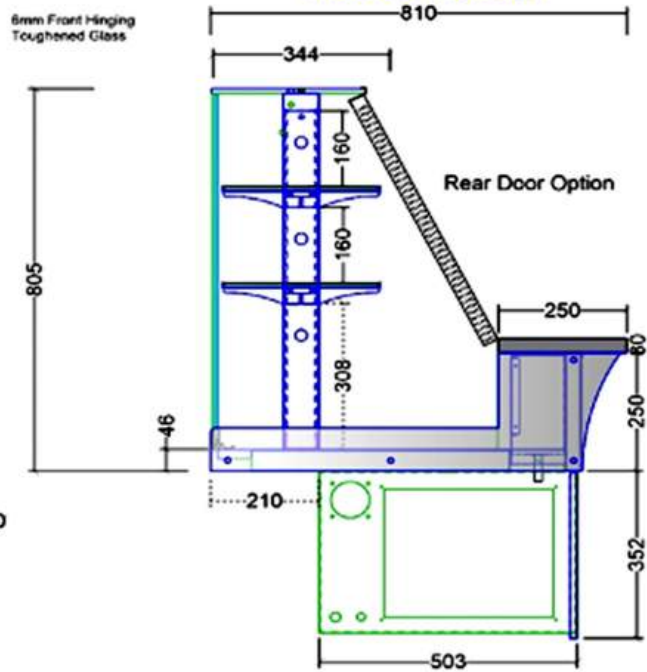

SIDE VIEW CC Drop-in-1S
Refrigerated Base
One Ambient Shelves

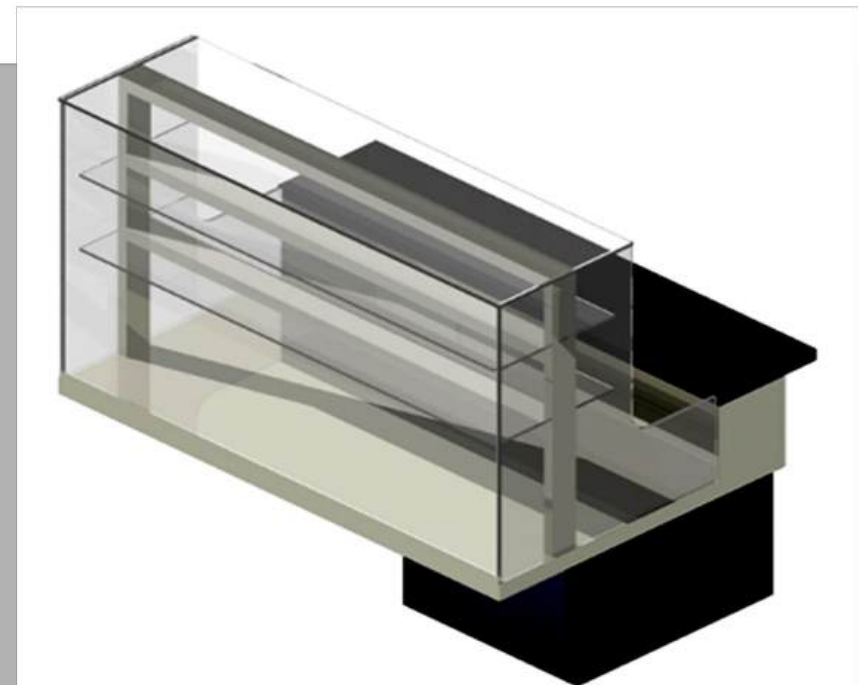
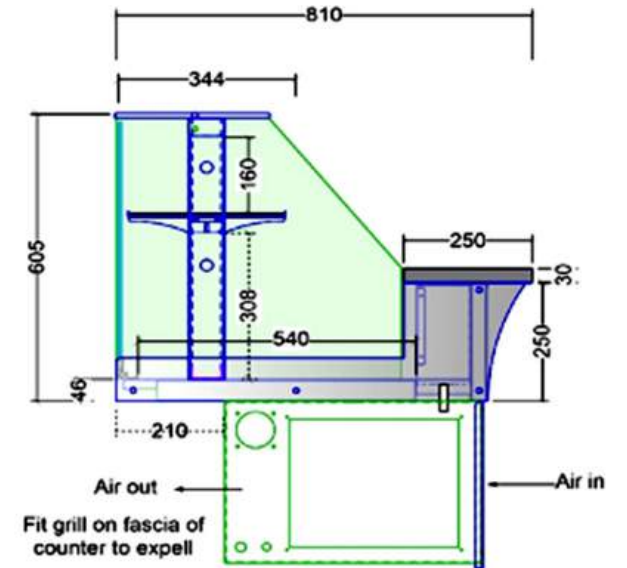

	Model	Dimensions	Power
One Shelf	CC800DIN-1S	800w x 810 x 605h	230v 5a
Two Shelf	CC800DIN-2S	800w x 810 x 805h	
	CC1000DIN-1S	1000w x 810 x 605h	230v 5a
	CC1000DIN-2S	1000w x 810 x 805h	
	CC1200DIN-1S	1200w x 810 x 605h	230v 8a
	CC1200DIN-2S	1200w x 810 x 805h	
	CC1600DIN-1S	1600w x 810 x 605h	230v 13a
	CC1600DIN-2S	1600w x 810 x 805h	
	CC1800DIN-1S	1800w x 810 x 605h	230v 13a
	CC1800DIN-2S	1800w x 810 x 805h	
	CC2000DIN-1S	2000w x 810 x 605h	230v 13a
	CC2000DIN-2S	2000w x 810 x 805h	
	VK1-Venting Kit	Use when fascia grill not fitted	



Type CC : Deli Dropin Template

TFSE PRODUCTS

If in doubt Call us 0800 6895517
E: Mail@tfse.eu

Ref:CC Dropin-Template
View: Plan

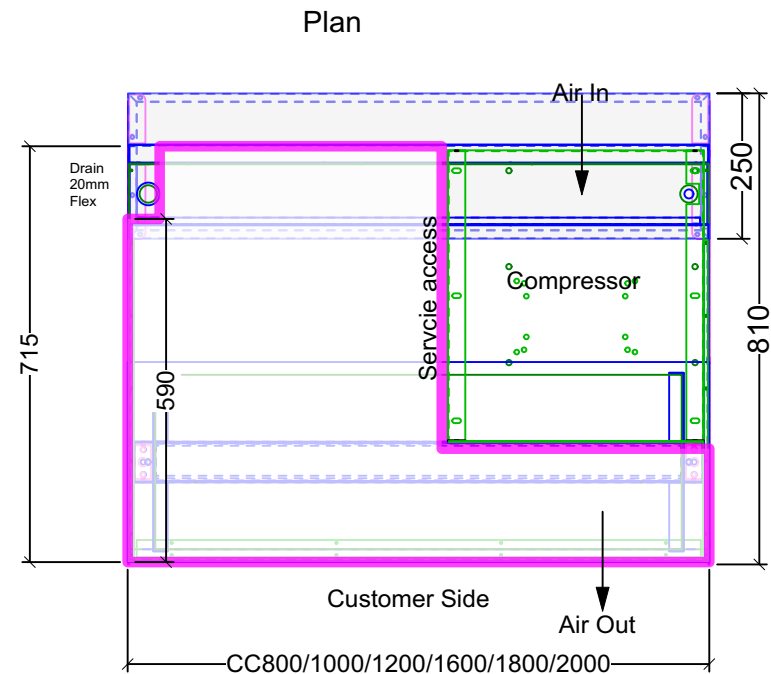
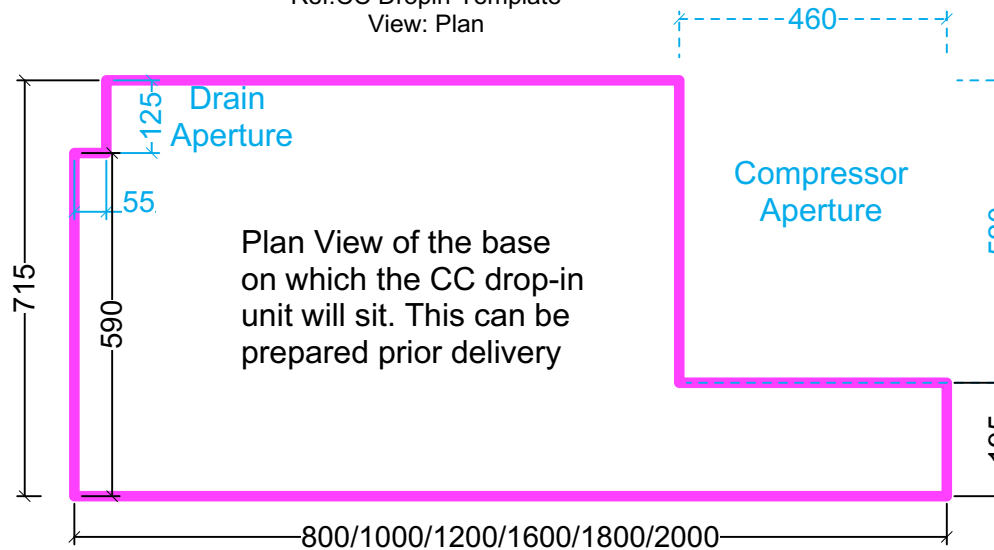

Side - Model 1S

Side - Model 2S

Front (Customer Side)

Rear cutting board height should match adjacent counter

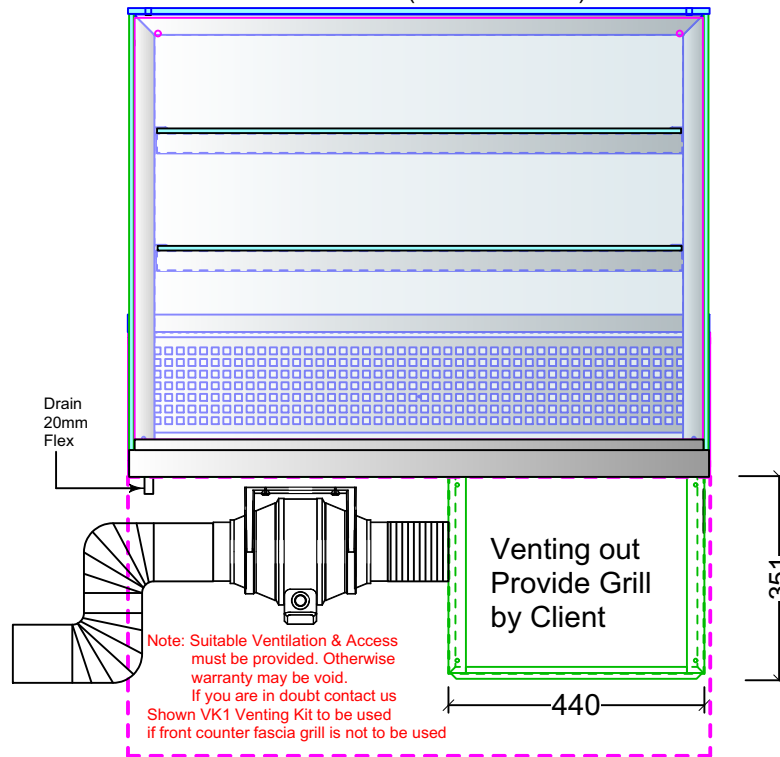
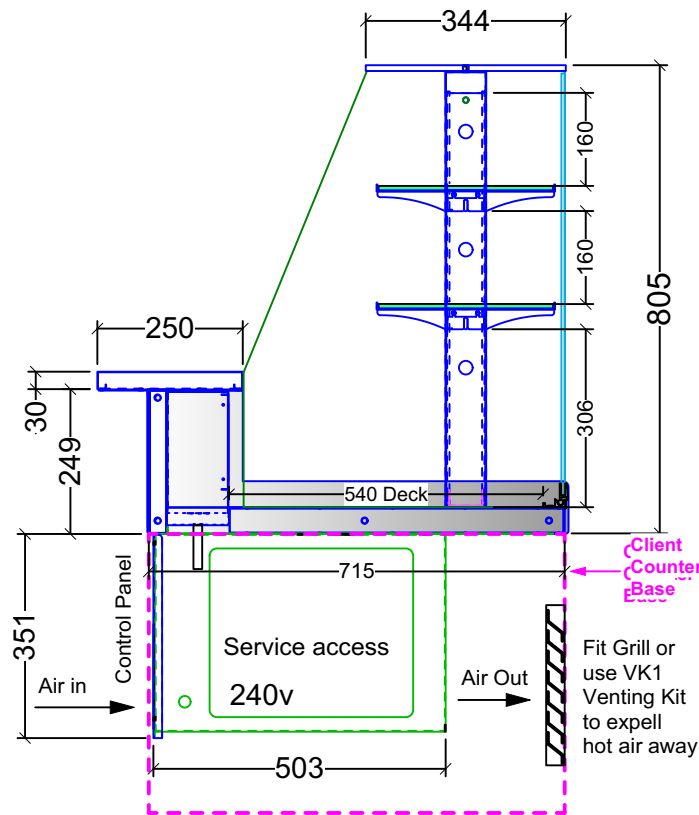
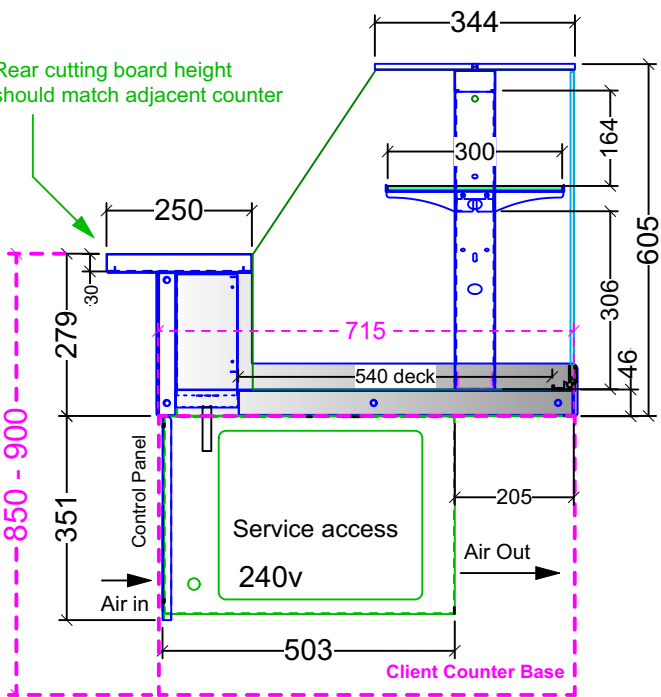



Typical Fitting



Rear Doors



Drop-in Examples

